

Crown OmniRemote Application Note

Badger Technology, Inc.

Part Number: AP01-20940-01

11-15-99 Rev. 2.0

Table of Contents

1. OmniRemote on Site Installation
2. Configuring the OmniRemote after installation w/Win95 Dial-Up Networking.
3. Configuring the Cisco Access Router to dial the OmniRemote
4. Accessing the OmniRemote via the Cisco Router using Telnet & DAD GUI
5. Sun Workstation CA Shim
6. Technician's Laptop interface to OmniRemote using Telnet & DAD GUI
7. Flash Eagle Cut Through Interface

1. OmniRemote On Site Installation

Installation

- a. For the Large NEMA cabinet, bolt NEMA cabinet to the wall with four bolts of sufficient strength to support cabinet. Figures 6. For the Mini NEMA cabinet, open the cabinet and remove 2 nuts holding the cover for the power supply. This will allow access to the lower right mounting hole and for the connections of the AC power leads. Bolt the Mini NEMA cabinet to the wall with four bolts of sufficient strength to support cabinet. Figure 8
- b. Unplug the OmniRemote power supply from the AC (large NEMA) outlet in the bottom of the cabinet.
- c. Connect the phone line into the IN connector on the AC Data System box. Route the phone wire out one of the liquid tight strain relief cord connectors. (Note: Run all wires coming into the NEMA cabinet through these cord connectors)
- d. Connect up the Outside (reader port 1) and Inside (reader port 2) Card readers to the DSC2 Card reader board per the attached Figure 1 drawing.
- e. Connect up the Door Strike to the DSC2 card reader board per the attached drawing Figure 1.
- f. Connect a RJ45 cable to the DSC2 card reader board per the attached Figure 1 drawing. Connect the RJ45 end of this cable to port 2 (SAM) on the OmniRemote (See Figure 2).
- g. Connect up the Motion Detector to +12VDC and the 66 block inside the NEMA cabinet per the attached Figure 3 drawing.
- h. Connect up the Smoke Detector to +12VDC and the 66 block inside the NEMA cabinet per the attached Figure 4 drawing.
- i. Connect the outside door Alarm contact to Bi63 and Ground Pin on the 66 block per the attached Figure 5 drawing (Note: The two middle columns on the 66 block are all ground pins).

- j. Connect a cable from the Flash unit to port 7 on the OmniRemote per the attached Figure 2 drawing.
- k. Wire AC power to the outlet box.

Verifying and Testing the Installation

- a. Connect the Battery/Power 10 pin connector to the AC power supply box in the Large NEMA cabinet. This connector is label with a tag which says "ATTACH THIS CONNECTOR PRIOR TO OPERATION". Connect the Red Battery lead in the Mini Nema Cabinet.
- b. Plug in the Power Supply into the AC outlet at the bottom of the Large NEMA Cabinet.
- c. Verify that the Ready LED on the OmniRemote Serial Alarm Module comes on within 1 minutes of power up. See the attached Figure 2 drawing for the large NEMA and Figure 8 for the Mini NEMA for the LED locations.
- d. Verify that the Off Hook LED on the OmniRemote comes on within 2 minutes. This LED should stay on for about 30 seconds. This Off Hook LED indicates that the OmniRemote called the Crown Operation Center and reported an "OmniRemote is alive" message for this OmniRemote.
- e. Call the Crown Operation Center and verify that this OmniRemote reported into the Crown CA system. Tell the Operation Center the Host Name, Phone number, and location of this OmniRemote (Note: The Host Name of the OmniRemote is printed on a label on the top of the OmniRemote). The temporary Tower name in the CA alarm report will be the TWR1.XXX (XXX=Digits in the Host Name of the OmniRemote. The Operation Center should log down the Host Name, Phone number and location of the OmniRemote. This information will be needed by the Operation center to configure the OmniRemote and the Router at a later time.
- f. Open the building door and verify that LED 15 on the OmniRemote Alarm Module comes ON within 20 seconds (The LED will delay about 15 seconds after the door is opened. See the attached Figure 2 drawing for LED locations. This LED indicate an outside open door alarm
- g. Swipe an access card through the Inside card reader. Verify that the buzzer sounds.
- h. Swipe an access card through the Outside card reader. Verify that the buzzer sounds and the door latch opens.
- i. Push the recessed alarm button on the Smoke Detector. Verify that the Alarm LED on the Smoke Detector comes on. Verify that LED 13 (BAM) on the OmniRemote Alarm Module is ON. Verify that within two minutes the Smoke Detector is reset and the alarm LED on the Smoke Detector and LED 13 on the OmniRemote are OFF. (Note: The OmniRemote resets the Smoke Detector by cycling power to the Smoke Detector by opening and closing OmniRemote control relay 1).
- j. Verify that LED 14 comes on when the Motion Detector detects motion. (Note: The LED on the Motion Detector will also flash when the Motion Detector detects motion).

- k. Verify that the Port 7 LED on the Serial Alarm Module is flickering OFF every 1 second (Note the flickers are very quick and may be hard to see). These flickers indicate that the Flash unit is sending alarm information to the OmniRemote.
- l. Unplug the Flash cable from port 7 on the back of the OmniRemote (See Figure 2). Verify that within 30 seconds the Off Hook LED on the OmniRemote comes on for about 15-30 seconds. The Off Hook LED coming on indicates that the OmniRemote called the Crown Operation Center and reported a "Loss_of_comm_with_Flash" Alarm.
- m. Plug back the Flash cable into port 7. Verify that within 30 seconds the Off Hook LED on the OmniRemote comes on for about 15-30 seconds. The Off hook LED coming on indicates that the OmniRemote called the Crown Operation Center and reported a Restore for "Loss_of_comm_with_Flash" Alarm.
- n. Call the Crown Operation Center and verify that this OmniRemote reported into the Crown CA system the above Flash Alarm and Restore for "Loss_of_comm_with_Flash".
- o. The OmniRemote is now operational and available to be placed into service to report alarms to the CA system. The alarms will be reported under the default Site and Tower names: Site Name = Omni1.XXX & TWR1.XXX (XXX=Digits in the Host Name of the OmniRemote). Perform section 2 below to change the default Site and Tower names.

2. Configuring the OmniRemote after installation w/Win95 Dial-Up-Networking.

A. Configuring and testing the OmniRemote with Windows Dialup Networking

- a. You must use a Window 95/98 Workstation with Dialup-Networking to configure the OmniRemotes for the first time. You must have a modem installed in this Workstation with access to an outside phone line. After you have configured the OmniRemote using the below procedure, you can set up the router to access the OmniRemote via the router's Dial-On-Demand. The below procedure tells you how to change the Site Name, Tower Name, PPP IP address and Date & Time of the OmniRemote.
- b. Set up Dial-up Networking
This application note presumes that your WIN95/98 workstation has already been configured for Dial-Up Networking. If not, refer to your WIN95/98 manual for creating Dial-Up Networking.
- c. Once your system has been configured for Dial-Up Networking, double-click on "My Computer" and open the folder labeled "Dial-Up Networking".

- d. Double click on the "New Connection" Icon. Follow the wizard for creating a new connection. Enter the site name and the phone number of the OmniRemote you are calling.
- e. When the wizard is finished a new Icon will be created with the site name in the Dial-Up Networking folder. Click the right mouse button on the new site name Icon and select Properties.
- f. Double check the phone number. Then select the "Server Type" tab at the top of the window. The type of Dial-Up server should be "PPP: Windows95, WindowsNT 3.5, Internet"
- g. Select only TCP/IP box at the bottom of the window. All other selections should be cleared.
- h. Click on the "TCP/IP Settings button". Select "Specify IP Address". Enter the IP Address of **10.0.0.2**
- i. Click "OK" to save and click "OK" to close.

You are now ready to make the connection to the OmniRemote.

- i. Double click on the site name Icon. Enter a username of **omni**. Enter a password of **omni***. Double check the phone number and click on the connect button.

When the connection has been established with the OmniRemote, the window will minimize to the menu bar in the lower right corner and show flashing terminals.

Note: After you call into the OmniRemote there is a 3 minutes timeout if there is no PPP IP activity for more then 3 minutes. After this 3 minutes of no activity, the OmniRemote will automatically disconnect the PPP connection.

- ii. At this point open the DAD Control GUI. Click on the start Menu, Programs, DAD Control, DAD Control.

B. Create the default DAD in the Control GUI

- a. Click on File in the upper left corner of the DAD Control Window. Click on New.
- b. Enter "Default" in the DAD Name field.
- c. Enter the default PPP IP address: **10.0.0.1** in the IP Address field.
- d. Click on Save.
- e. Select this "Default" DAD Name when you want to connect to a OmniRemote that still has the default PPP IP address.

C. Connect to the OmniRemote

- a. Highlight the OmniRemote name "Default" from the picklist of existing DADs.
- b. Click on File and Connect in the upper left hand corner of the Control Window.
- c. Enter the username of **root**
- d. Enter the password of **badger***
- e. A message stating "Connected to hostname at 10.0.0.1 will appear at the bottom of the Control window. This will take a few minutes due to Dial-Up networking.

D. Change Time

- a. Click on function and administration at the top of the Control Window.
- b. Select Set Time tab on the Administration window.
- c. Select the proper timezone from the picklist in the Timezone Field.
- d. Select the correct Hour, Minute, Second and click on the "Save Time" button.
- e. Click on file and Close to close the Administration window.

This function will set the time on the Serial Alarm Module. To set the time for the Bistate and Analog alarms, the time must be downloaded to the Bistate Analog Module. (See Step F.)

E. Change Tower and Site names

- a. Click on Functions and Flow Construction from the top of the Control Window. This will bring up the flow window. The flow window consists on many components representing the flow of data through the OmniRemote.
- b. Click the right mouse button on the component labeled "CROWNIO"
- c. Very Carefully select properties. **Caution: DO NOT** click on Remove. This will lose all your configuration information in this remote.
- d. Modify the Tower Name
- e. Modify the Site Name
- f. Verify the Phone corresponds to that of the Access Router.
- g. Click on the save button. Wait until the Flow window refreshes.
- h. Click on the close button. This will close the CROWNIO Configuration window.

F. Download Time to the Bistate Analog Module

- a. Click the right mouse button on the component labeled "BAMTONMS"
- b. Very Carefully select properties. **Caution: DO NOT** click on Remove. This will lose all your configuration information in this remote. Select "Set Time" from the picklist labeled "Set Time"
- c. Select "Download Config" from the picklist labeled "Operation"

- d. Click on the Save Button. Wait until the Flow Window Refreshes.
- e. Click on the close button. This will close the BAMTONMS configuration window.
- f. Click the right mouse button on the component labeled “BAMIO”
- g. Very Carefully select disable. **Caution: DO NOT** click on Remove. This will lose all your configuration information in this remote.
- h. Click the right mouse button on the component labeled “BAMIO”
- i. Very Carefully select enable. **Caution: DO NOT** click on Remove. This will lose all your configuration information in this remote.

G. Verify Flash communications

- a. Click the left mouse button on the component labeled “FLASHIO”
- b. Select “Raw” from the picklist in the Log Window at the upper Right of the Flow Window. This will create a log component connected to FLASHIO.
- c. Click the right mouse button on the green component labeled “Raw”.
- d. Select View Log.
- e. Click on the “Get Records” button in the View Logs Window. Verify that data is in the log. If there is data, the OmniRemote is communicating with the Flash unit. If there are no records, there is a problem with the communications between the Flash and the OmniRemote.
- f. After verification that record exist, click the right mouse button on the Raw component.
- g. Select Remove.

H. Verify last card read

- a. Have Installer swipe an entry card through the reader.
- b. Click the right mouse button on the component labeled “dscardCOMP”
- c. Very Carefully select properties. **Caution: DO NOT** click on Remove. This will lose all your configuration information in this remote.
- d. Verify that the “Last Card Read” field corresponds to card just swiped.
- e. Click on the close button.

I. Verify state of BiState Alarms Smoke Detector, Motion Detector, Door Alarm, Cabinet Door.

- a. Click the right mouse button on the component labeled “BAMTONMS”
- b. Very Carefully select properties. **Caution: DO NOT** click on Remove. This will lose all your configuration information in this remote.
- c. Verify that the state of the Smoke Detector and Door Alarm points are Correct.
- d. Verify the state of the Motion Detector point.
- e. Click on the close button.
- f. Select file and close on the Flow window.

- g. Select file and disconnect on the Control window.
- h. Select file and exit from the Control window. This will exit the DAD Control Program.

J. Telnet into OmniRemote at the default PPP IP address of 10.0.0.1

- a. Click “connect” in the upper left corner of the window. Select Remote System”.
- b. Enter 10.0.0.1 in the host field. Click on the “Connect” button.

You should now get a username prompt from the LynxOS (Host Name)

- c. The Username is **root**
- d. Password is **badger***

K. Checking the Version of the Crown Script set on the OmniRemote

- a. Check the CrownVER file on the OmniRemote to see if you have the current Crown script set loaded on the OmniRemote. This file shows all the versions of the Crown scripts, which are loaded on the OmniRemote. At the top of this file there is a Version for the Crown Configuration. This is the version of the set of Crown scripts which are loaded on the OmniRemote. If this Crown Configuration Version set is not the current version, you need to download the current Crown script set.
 - i. To check the CrownVER file you must enter the following command after you get the **bash** prompt.

```
cat /opt/ds/CrownVER
```

The following is an example Telnet screen showing the Crown Configuration Version file, CrownVER:

```
bash-2.02# cat /opt/ds/CrownVER
#   Crown Configuration Version: 1.1.2   Date: 1999/11/05
#
#   Crown Configuration contains the following version of files
#
#       /opt/ppp/options                version 1.4   1999/09/10
#       /opt/ppp/options.dialin         version 1.1   1999/09/10
#       /opt/ds/crown/crownIO.py        version 1.15  1999/11/02
#       /opt/ds/discard/discardComp.py  version 1.2   1999/11/06
#       /opt/ds/discard/discardIO.py    version 1.2   1999/11/06
#       /opt/ds/flashunit/flashComp.py  version 1.7   1999/11/06
#       /opt/ds/flashunit/flashIO.py    version 1.4   1999/11/06
#       /opt/ds/crownlogic/CrownLogic.py version 1.1   1999/11/06
bash-2.02#
```

L. Downloading a new Crown Script set to the OmniRemote

Periodically modifications will need to be made to the scripts running in the OmniRemote. Badger will ship out an upgrade diskette or CD ROM with these new scripts. Follow the below procedure to install these new scripts.

- a. Open a DOS prompt window.
- b. If the Cisco 3620 router has the Dialer Map and IP route configured for the remote you want to download to, then Ping the remote with the following Ping command to force the router to make a connection to the OmniRemote. If you do not have the router configured for this OmniRemote then connect to the OmniRemote using Win98 Dial-Up-Networking (See section 2A for Dial-Up-Networking procedure).

Ping -t xxx.xxx.xxx.xxx (xxx.xxx.xxx.xxx = IP address of OmniRemote)

Within 30 seconds you should start seeing the Ping Replies from the OmniRemote, which indicates that the Cisco 3620 Router has made a networked connection to the OmniRemote. At this time press <Ctrl-C> to end the ping command.

Note: After you call into the OmniRemote there is a 3 minutes timeout if there is no PPP IP activity for more than 3 minutes. After this 3 minutes of no activity, the OmniRemote will automatically disconnect the PPP connection.

- c. Install the Upgrade diskette or CD in the appropriate drive on your workstation.
- d. Type the device letter of the Diskette or CD drive followed by a colon.
A:
At the prompt type:
ftp xxx.xxx.xxx.xxx (xxx.xxx.xxx.xxx = IP address of OmniRemote)
- e. Login in to the OmniRemote as
username: **root**
password: **badger***
- f. Set ftp for binary mode by typing
ftp> **bin**
- g. Move the new upgrade scripts over to the OmniRemote.

ftp> **mput ***

You will be prompted for each file that is to move. Answer **y** to each prompt.

- h. Close the ftp session by typing quit at the prompt.

```
ftp> quit
```

- i. Open a telnet session to the OmniRemote.

Click on the start button on the menu bar and click on run. Enter telnet xxx.xxx.xxx.xxx. Where xxx.xxx.xxx.xxx is the IP address of the OmniRemote to be upgraded. This will open a Telnet window.

- j. Login to the OmniRemote.

```
username: root
password: badger*
```

- k. At the prompt run the install program.

```
bash-25x: install.upgrade
```

- l. Logout of the OmniRemote.

```
bash-25x: exit
```

- 1. Record in a log the new Crown Configuration Version of this OmniRemote.

M. Change the PPP address of the OmniRemote

To change the PPP address of the OmniRemote, you must run the program **netconfig**.

- a. After login, you will receive a **bash** prompt. Enter the following command:

```
 /opt/bin/netconfig
```

 - 1. Edit hostname: *current hostname*
 - 2. Ethernet
 - 3. PPP
 - 4. Gateway
- b. The hostname is set at the Factory and is configured to match your Access Router. **Do Not** Change the hostname.
- c. Enter 2 if you want to change the default LAN IP Address of 192.168.1.1 and the default Netmask, 255.255.0.0 of the OmniRemote. Enter the IP Address and NetMask of the Physical 10baseT port of the OmniRemote.
- d. Enter 3 to change the PPP IP address of the Dial-Up Link to the OmniRemote. **Do not** disable pppComm or Com1 CD Monitor. These functions must be enabled for the OmniRemote to work over a dial-up link. (Note: Refer to the Router configuration file "running-config" on the SUN computer to find the next available PPP IP address for the region of the OmniRemote).
- e. The gateway feature is not implemented at this time.

- f. Save changes and Reboot. The OmniRemote must be rebooted for the above changes to take effect.

3. Configuring the Cisco Access Router to dial the OmniRemote

- a. The configuration for the Cisco 3620 router is kept on the SUN computer under the file /tftpboot/running-config. When the router is booted it reads the file running-config into the router's memory via tftp.
- b. After installing a new OmniRemote you need to add a dialer map and ip route for the new OmniRemote to the router. This will allow you to call into the OmniRemote using the router. The router has been pre configured with the first 500 Users Names/Password for the first 500 OmniRemotes, therefore the router is already set to accept alarms from the first 500 OmniRemotes and you do not need to make any changes to the router to start sending in alarms from a new remote.
- c. Logon to the SUN console using the User Name: root and Password: badger*
- d. Bring up the File Manager by double clicking on the file cabinet ICON.
- e. Double click on the tftpboot file folder.
- f. Select the file running-config with a single left mouse click.
- g. Select "Selected" on the top menu bar.
- h. Make a backup copy of the current running-config file by selecting "Copy to" Change "Name for Copy" to running-config mm dd yy. (mm dd yy = current date).
- i. Double click on the file "running-config" to edit your changes.
- j. Edit the information for the OmniRemote is in the following three lists.
- k. **List 1: Username and Passwords.** For each new OmniRemote you must add the username and password line. The username is the Host Name of the OmniRemote. (Note: The Host name can be found on a label on the OmniRemote and is in the format of crownXXX). The username and password lines for the first 500 OmniRemotes have already been entered on 11/5/99. The username and password lines are the only required information for the OmniRemote to call into the router and report its Alarms. The following is the format of the User Name/Password line:

```
username crown2 password 0 omni*
```

- l. **List 2: Dialer Maps.** There are sample dialer maps for each region. The samples are commented out with an ! in the front of the line. To make the sample dialer map active you must delete the ! in the front of the line. To bring an OmniRemote on-line, find the next available IP address in the region which the OmniRemote is located. Delete the ! in the front of the line. Change the DIAL phone number from # to the phone number of the OmniRemote. Format = DIAL 1-XXX-XXX-XXXX . Change the name from crown### to the Host Name of the OmniRemote (Note: The Host Name can be found on a label on the OmniRemote and is in the format of: crown###. Enter the site location above the dialer map. If there is not a sample map

available, use the copy and paste to make up a sample and make the above changes. To copy and paste, Select the text with the left mouse button, Press Ctrl-C to copy to the paste buffer and press Ctrl-V to paste the text back into the document. Each Region shows the Range of IP addresses available for the Region. Do not use IP addresses X.X.X.0 OR X.X.X.255. The following is the format of the Dialer Map:

!Site Location: Field Trial, Crown Lab

```
dialer map ip 10.27.0.1 name crown2 modem-script DIAL 746-5994
```

- m. **List 3: ip routes.** There are sample ip routes for each region. The samples are commented out with a ! in the front of the line. To make the sample ip route active you must delete the ! in the front of the line. To bring an OmniRemote on-line, find the corresponding ip route to the above dialer map for the new OmniRemote and delete the ! in the front of the line. If there is not a sample ip route available, use the cut and paste to make up a sample and make the above changes. Each Region shows the Range of IP addresses available for the Region. Do not use IP addresses X.X.X.0 OR X.X.X.255

```
ip route 10.27.0.2 255.255.255.255 Dialer1
```

- n. After you have made all your changes, save the file by selecting "File" from the top menu bar and select "Save". Select "File" and then "Close".
- o. The router must be rebooted before the above changes will take affect. Reboot the router by turning the power switch off on the Router and back on. (**Caution:** When you turn off the router you will lose all the current connections to the OmniRemotes which may be connected at the time. The router should only be powered down when there are no connections to the OmniRemotes though the modem lines. The LED on the back of the Router next to the phone line connectors show if the modems are connected to an OmniRemote. Power down the Router when there are no LEDs ON, next to the phone line connectors.)
- p. Refer to section 4 to test out the router Dial-On-Demand connection to your new OmniRemote.

4. Accessing the OmniRemote via the Cisco Router using Telnet & DAD GUI

- a. If your Windows 95 workstation has a route to the Cisco 3620 OmniRemote router you can access the OmniRemotes via the router modems.
- b. To access the OmniRemote via the router, just bring up the DAD GUI or Telnet and enter the PPP address of the OmniRemote. The router will see the IP demand on the LAN for the OmniRemote PPP address and will automatically place a call to the OmniRemote using Dial-On-Demand and log into the OmniRemote and provide an IP connection.
- c. Note: After you call into the OmniRemote there is a 3 minutes timeout if there is no PPP IP activity for more then 3 minutes. After this 3 minutes of no activity, the OmniRemote will automatically disconnect the PPP connection.

5. Sun Workstation CA Shim

- a. You can set up a workstation that has a route to the Sun Workstation to view the Alarm log which is routed to the CA system.
- b. Telnet or use HyperTerminal TCP/IP (winsock) mode to access the SUN CA shim computer. Enter the SUN IP address 172.28.2.8 in the Telnet window. See below for instructions to set up HyperTerminal to access the SUN via TCP/IP.
- c. Log into the SUN as User: root and Password: badger*.
- d. Enter the command: cd /var/log
- e. Enter the command tail -f syslog
- f. The alarms will be displayed on your workstation

- g. Setup for using HyperTerminal TCP/IP to access the SUN system Shim.
 1. Run HyperTerminal program hypertrm.exe
 2. Enter "SUN CA Shim" for Name
 3. Select connect using TCP/IP (winsock)
 4. Enter SUN IP address: 172.28.2.8
 5. Select properties ICON (Far right ICON)
 6. Select settings
 7. Select Emulation = VT100
 8. Select Terminal Setup
 9. Select 132 column mode
 10. Select OK
 11. Select OK
 12. Select View, Font, Size 9, OK
 13. Select File Save
 14. Select File Exit
 15. Select "SUN CA Shim" ICON under HyperTerminal folder.
 16. Log into the SUN as User: root and Password: badger*.
 17. Enter the command: cd /var/log
 18. Enter the command tail -f syslog
 19. The alarms will not be displayed on your workstation

6. Technician's Laptop interface to OmniRemote using Telnet & DAD GUI

- a. Connect a Cat 5 cross-over cable to the LAN port of the laptop and the other end to the Ethernet port on the SAM board (Figures 2 & 8).
- b. Set your Control Panel Network TCP-IP Ethernet Properties to IP address pf 192.168.1.2 and Subnet Mask of 255.255.0.0
- c. Startup the DAD GUI or Telnet. Select the default LAN IP address 192.168.1.1

7. Flash Eagle Cut Through Interface

- a. Double click on the Dial-up IP ICON on the right side of the Win98 menu bar.
 - b. Set your IP address of Server to the PPP address of the OmniRemote. Set Port # to 6040. Select RAW TCP connection only. Select configure from the Dial-Out-IP menu bar. Select Trace Window. Select Enable Trace on Trace window.
 - c. Connect to the Remote via Windows Dial-up Networking or using the Router. To make the router connect to the OmniRemote bring up a DOS Window and PING the OmniRemotes PPP address. Continue to PING until you start to get replies.
 - d. After you get a reply from your PINGs then bring up the Eagle Software by double clicking on the Eagle ICON on the desktop.
 - e. Select the Serial ICON on the Eagle menu bar.
 - f. Enter Name: Root Enter Password: badger* Enter ID: FlashIO
 - g. Select Login
 - h. When the "Enter Password box" comes up, select the OK.
8. If the Eagle software does not come up the first time, close down the Eagle software and try again. Review the Trace Log if you continue to have problems logging onto the Flash system. The Trace Log shows all the commands and responses between the Eagle software and the Flash unit.

DSC2 Card

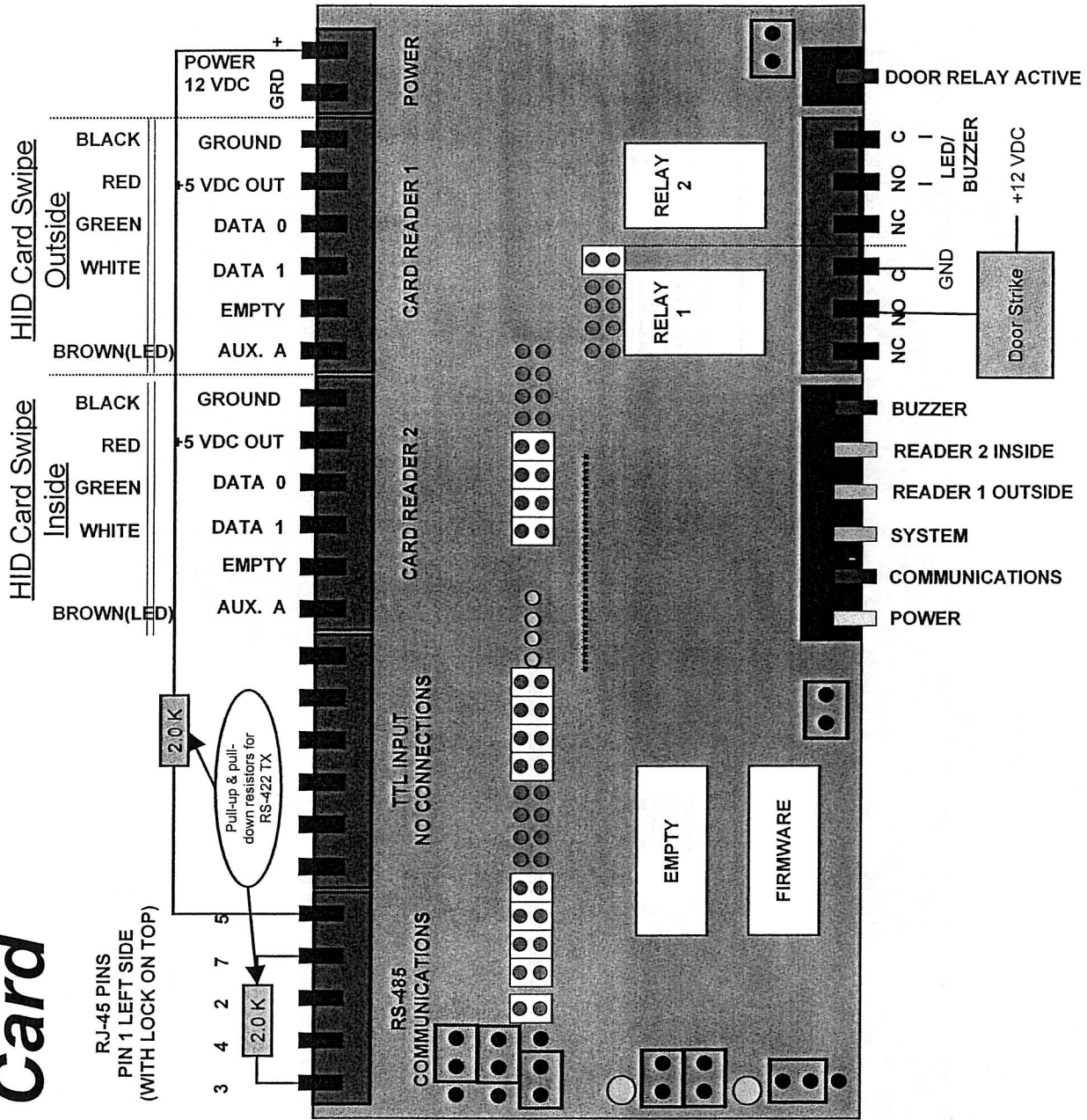

Figure 1

Crown System (Remote Site)

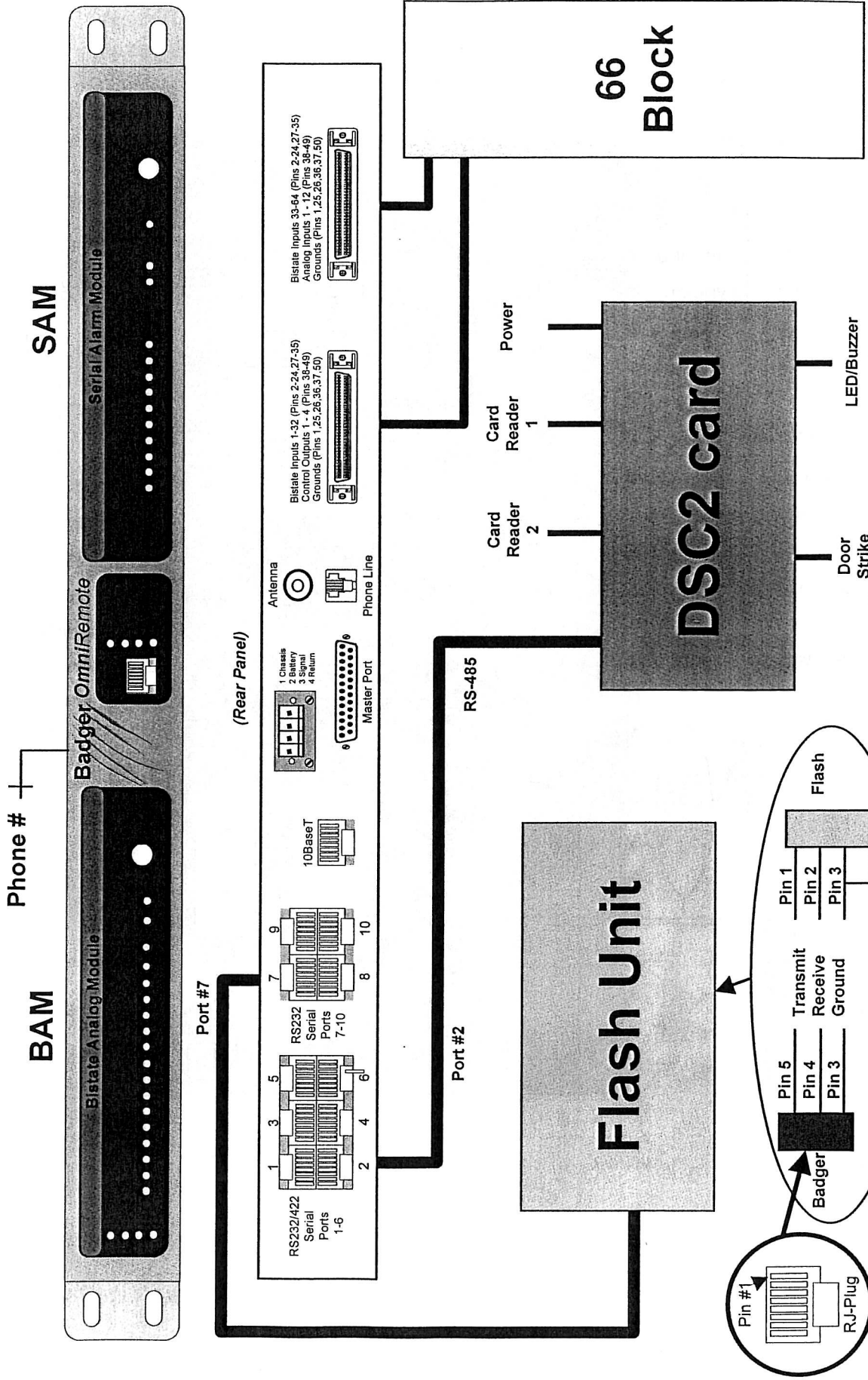

Figure 2

ADEMCO 998PI Motion Detector

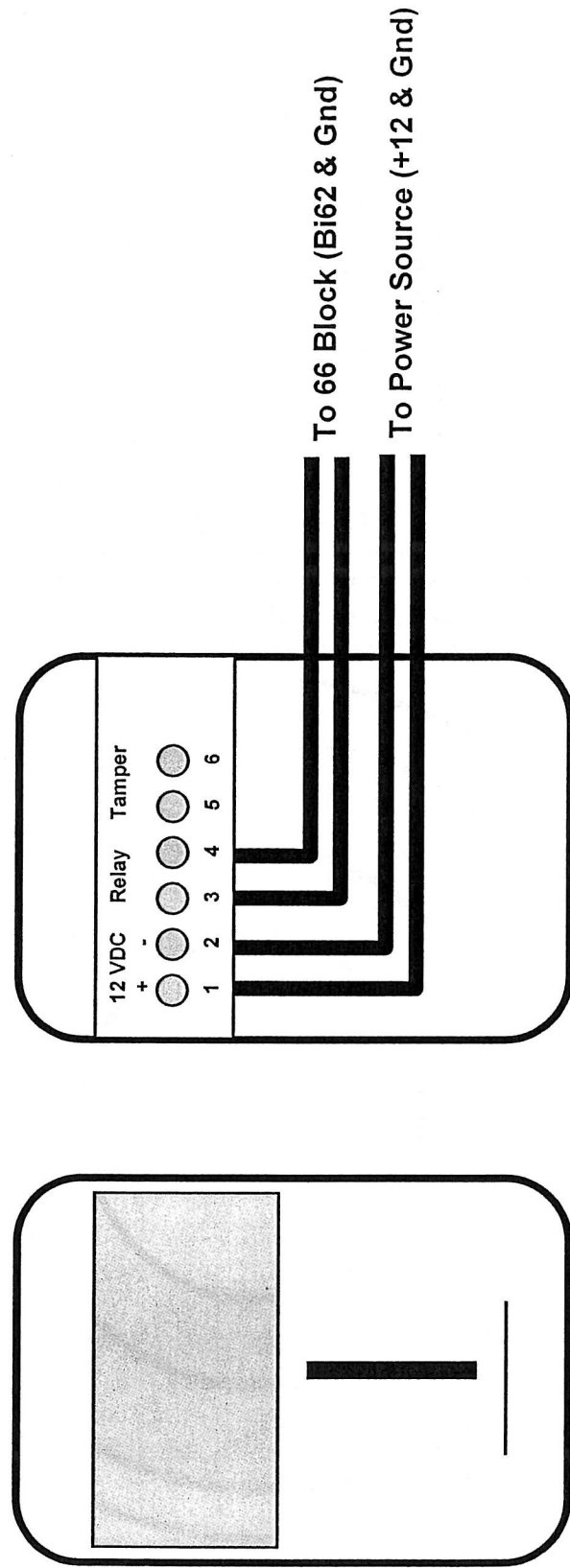

Figure 3

BRK Smoke Detector

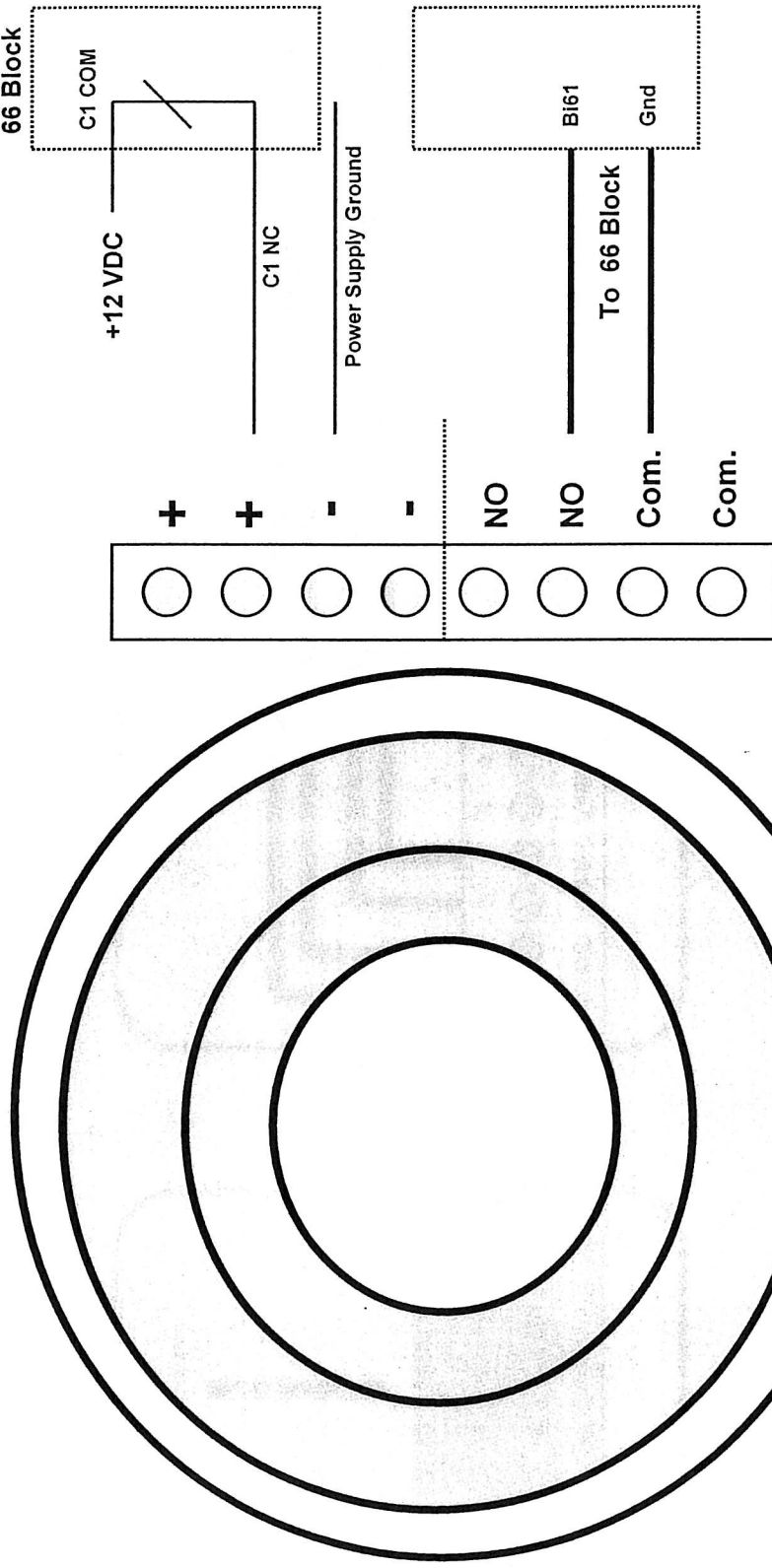

Figure 4

66-Block Pin-outs

Badger OmniRemote 66 BLOCK PIN-OUTS

Point Description	Gnd	Gnd	Gnd	Gnd	Point Description
	Bi 1	Gnd	Bi 33		
	Bi 2	Gnd	Bi 34		
	Bi 3	Gnd	Bi 35		
	Bi 4	Gnd	Bi 36		
	Bi 5	Gnd	Bi 37		
	Bi 6	Gnd	Bi 38		
	Bi 7	Gnd	Bi 39		
	Bi 8	Gnd	Bi 40		
	Bi 9	Gnd	Bi 41		
	Bi 10	Gnd	Bi 42		
	Bi 11	Gnd	Bi 43		
	Bi 12	Gnd	Bi 44		
	Bi 13	Gnd	Bi 45		
	Bi 14	Gnd	Bi 46		
	Bi 15	Gnd	Bi 47		
	Bi 16	Gnd	Bi 48		
	Bi 17	Gnd	Bi 49		
	Bi 18	Gnd	Bi 50		
	Bi 19	Gnd	Bi 51		
	Bi 20	Gnd	Bi 52		
	Bi 21	Gnd	Bi 53		
	Bi 22	Gnd	Bi 54		
	Bi 23	Gnd	Bi 55		
	Gnd	Gnd	Gnd		
	Gnd	Gnd	Gnd		
	Bi 24	Gnd	Bi 56		
	Bi 25	Gnd	Bi 57		
	Bi 26	Gnd	Bi 58		
	Bi 27	Gnd	Bi 59		
	Bi 28	Gnd	Bi 60		
	Bi 29	Gnd	Bi 61	Smoke Detector	
	Bi 30	Gnd	Bi 62	Motion Detector	
	Bi 31	Gnd	Bi 63	Door Alarm	
	Bi 32	Gnd	Bi 64	OmniRemote Cabinet Door	
	Gnd	Gnd	Gnd		
	Gnd	Gnd	Gnd		
	+ Power for Smoke Detector	C1 NC	Gnd	Ana 1	
	+12 VDC	C1 Cm	Gnd	Ana 2	
		C1 NO	Gnd	Ana 3	
		C2 NC	Gnd	Ana 4	
		C2 Cm	Gnd	Ana 5	
		C2 NO	Gnd	Ana 6	
		C3 NC	Gnd	Ana 7	
		C3 Cm	Gnd	Ana 8	
		C3 NO	Gnd	Ana 9	
		C4 NC	Gnd	Ana 10	Outside Temperature
		C4 Cm	Gnd	Ana 11	OmniRemote Cabinet Temperature
		C4 NO	Gnd	Ana 12	AC Line Detection
		Gnd	Gnd	Gnd	

Figure 5

OmniRemote NEMA Cabinet

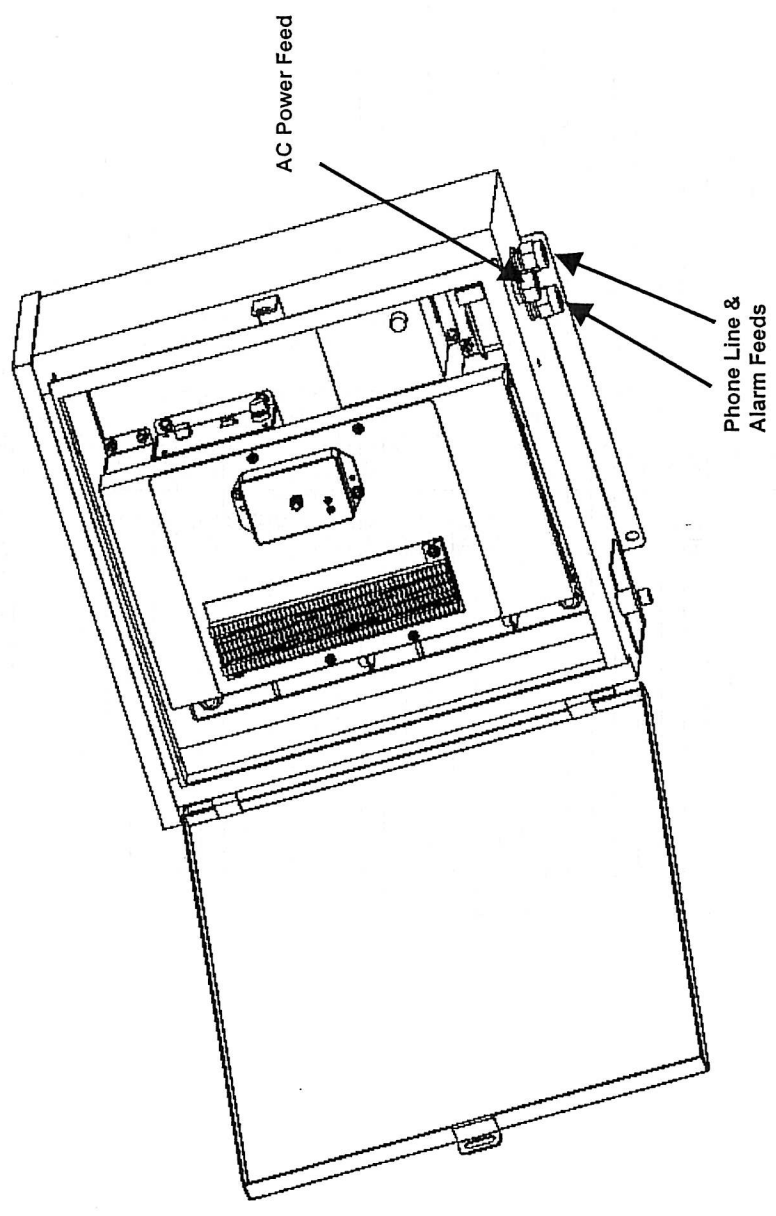

Figure 6

OmniRemote NEMA Details

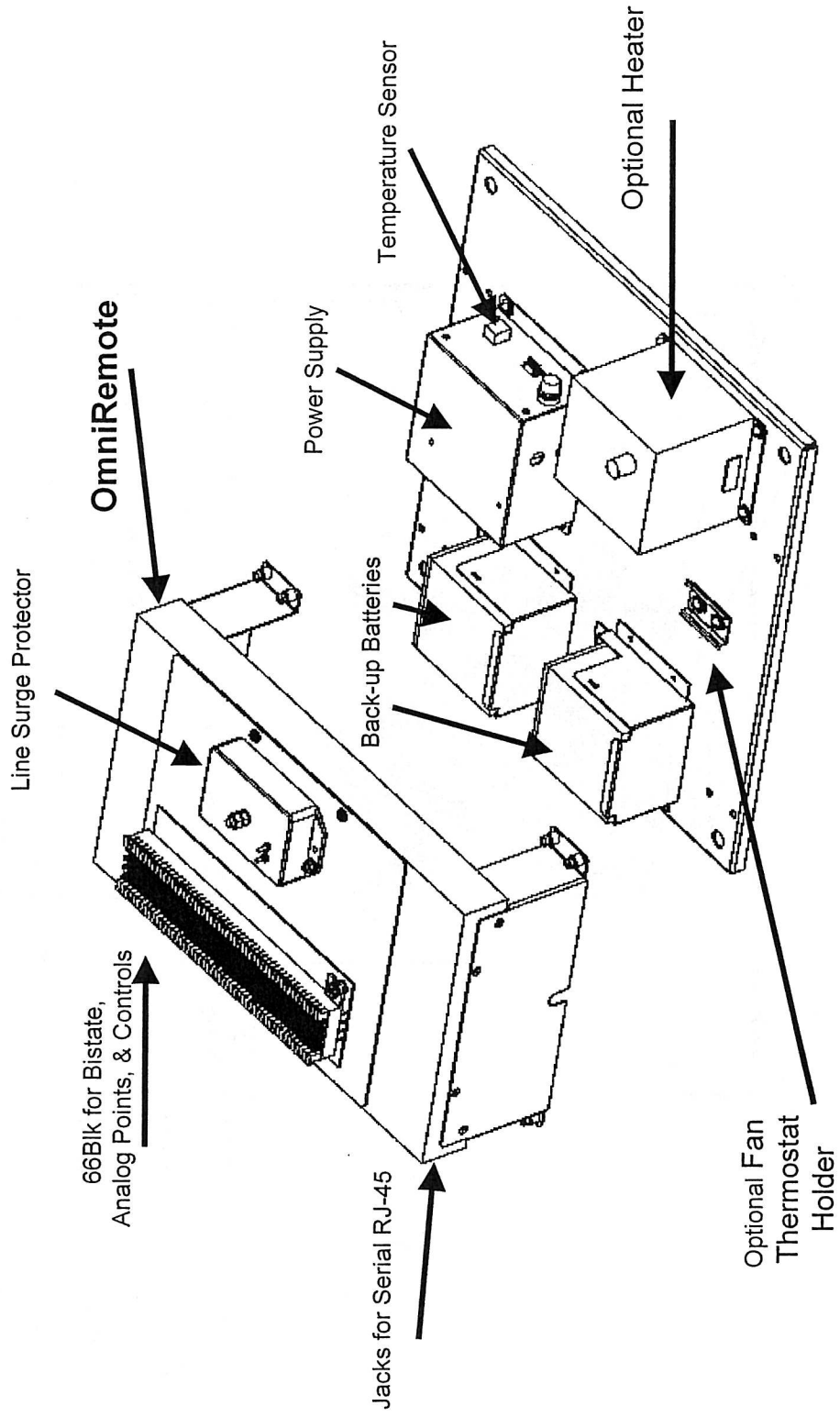

Figure 7

Mini OmniRemote Cabinet

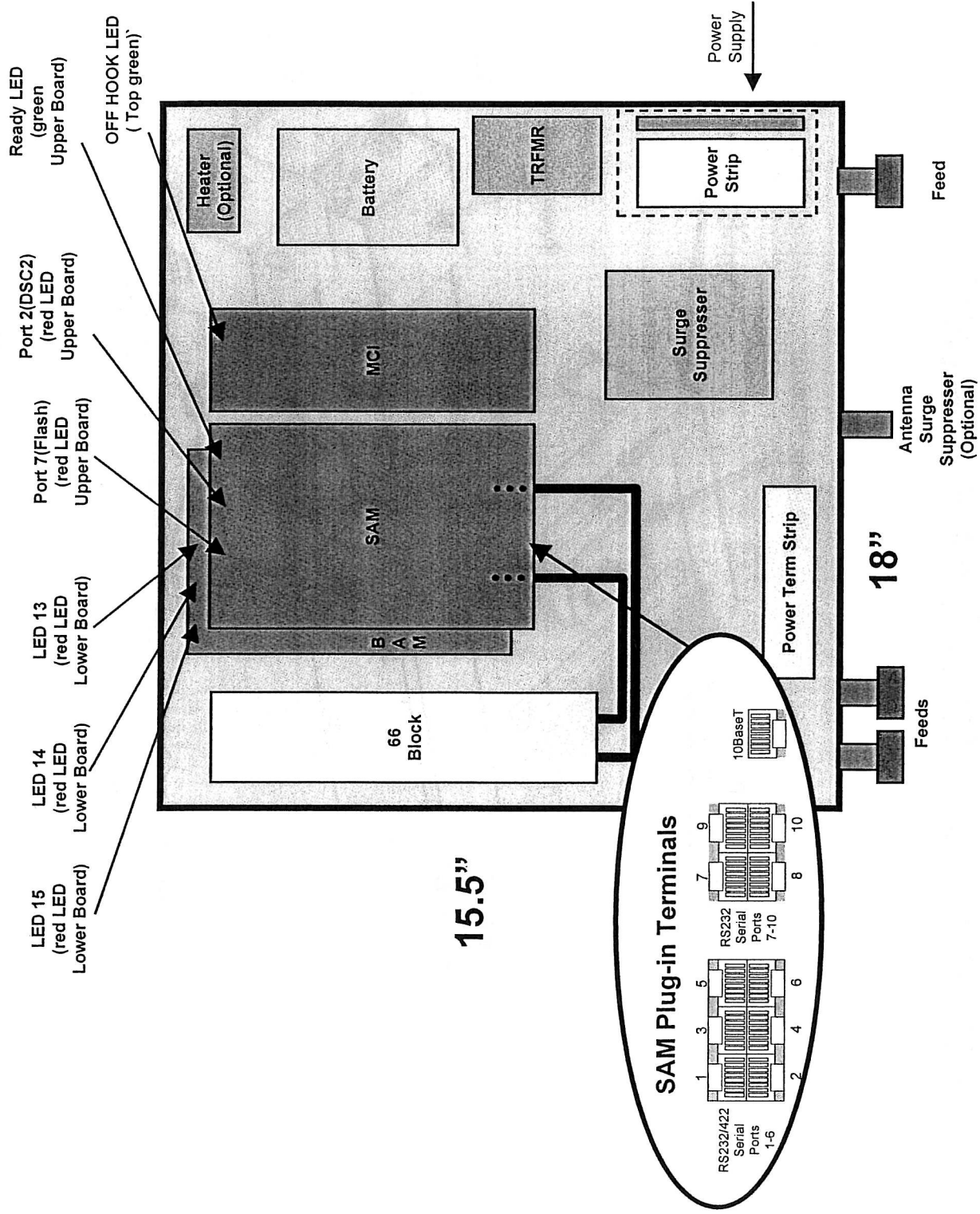

Figure 8