

Part Number	Description
HS24D10C	10A, 280 Vac
HS24D10N	10A, 280 Vac
HS60D10C	10A, 600 Vac
HS60D10N	10A, 600 Vac

Part Number Explanation



NOTES

- 1) Line Voltage: 24 = 280 Vac; 60 = 600 Vac
- 2) Switch Type: D = Zero cross turn-on
- 3) Control Range: C = 4-14 Vdc; N = 8-32 Vdc

MECHANICAL SPECIFICATION

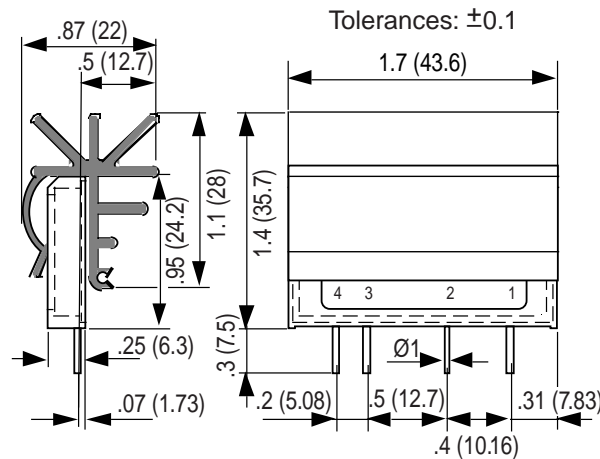

WEIGHT:
1.06 oz. (30g)

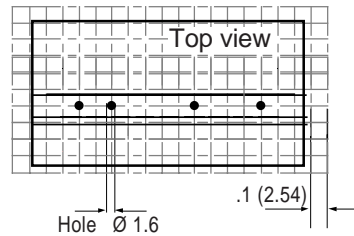

Figure 1 — HS relays (dimensions in mm)



FEATURES/BENEFITS

- Industry standard package
- Integrated heat sink
- Over-sized thyristor rating
- Direct-bonded copper technology

DESCRIPTION

These solid-state single inline package (SIP) relays are designed for mounting on printed circuit boards. The Series HS relay is designed with 16A and 25A thyristors. The HS can switch permanent 16A or 25A with forced air convection. They can withstand very high current overloads. The relays incorporate a direct-bonded copper substrate along with an integrated heat sink. This technology offers outstanding thermal efficiency as well as thermal stress performance.

APPLICATIONS

- Motor control — Pumps, reversing, integration of relays in terminal boxes
- Lamp control — Infrared drying, traffic lights, theater lighting

APPROVALS

Series HS relays are pending UL recognition.

BLOCK DIAGRAM

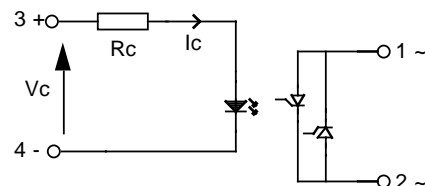

Figure 2 — HS relays

INPUT (CONTROL) SPECIFICATION

	Min	Max	Units
Control Range			
HSXXDXXC	4	14	Vdc
HSXXDXXN	8	32	Vdc
Input Current Range			
HSXXDXXC	6.5	30	mAdc
HSXXDXXN	3.5	18	mAdc
Must Turn-Off Voltage			
All relays		1	Vdc
Input Resistance (Typical)			
HSXXDXXC		440	Ohms
HSXXDXXN		1640	Ohms

OUTPUT (LOAD) SPECIFICATION

	Min	Max	Unit
Operating Range			
HS24	12	280	Vrms
HS60	24	600	Vrms
Peak Voltage			
HS24		600	Vpeak
HS60		1200	Vpeak

Load Current Range	Min	Max	Unit
HS24	.005	16*	Arms
HS60	.005	25*	Arms

*See Note 2.

Maximum Surge Current Rating (Non-Repetitive)
(See Figure 5)

HS24	160	Apeak
HS60	300	Apeak

On-State Voltage Drop	Min	Max	Unit
All relays		1.6	V

Zero Cross Window (Typical)	Min	Max	Unit
All relays		12	V

TYPICAL APPLICATIONS

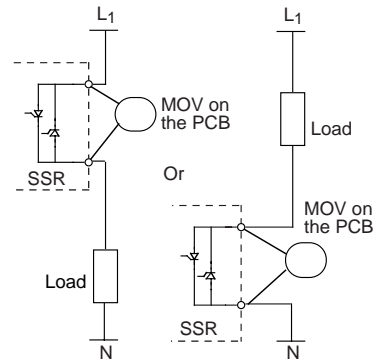

Figure 3 — HS relays

CONTROL CHARACTERISTICS

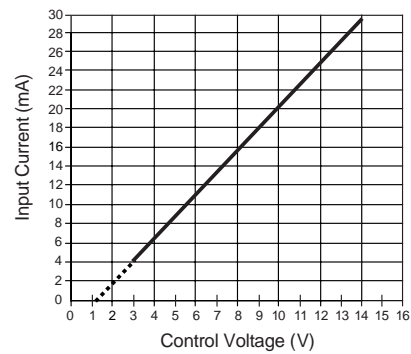

Figure 4a — HSXXDXXC relays

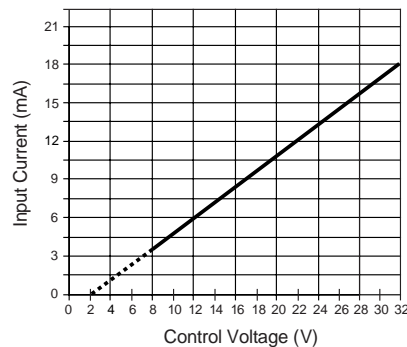

Figure 4b — HSXXDXXN relays

OUTPUT (LOAD) SPECIFICATION (Continued)

	Min	Max	Unit
Off State Leakage Current (60Hz)			
All relays		1	mA
Turn-On Time (60Hz)			
All relays		8.3	ms
Turn-Off Time (60Hz)			
All relays		8.3	ms
Off-State dv/dt			
All relays		500	V/ μ s
Off-State di/dt			
All Relays		50	A/ μ s
Operating Frequency			
All relays	10	440	Hz
I²t for match fusing (<8.3ms)			
HS24		128	A ² S
HS60		450	A ² S

ENVIRONMENTAL SPECIFICATION

	Min	Max	Unit
Operating Temperature	-40	80	°C
Storage Temperature	-40	120	°C
Input-Output Isolation	4000		Vrms
Output-Case Isolation	3300		Vrms

NOTES:

1. Electrical specifications at 25°C unless otherwise specified.
2. Maximum current limited by heat sink and printed circuit board.
3. For 800Hz applications, contact factory.
4. For additional/custom options, contact factory.

SURGE CURRENT

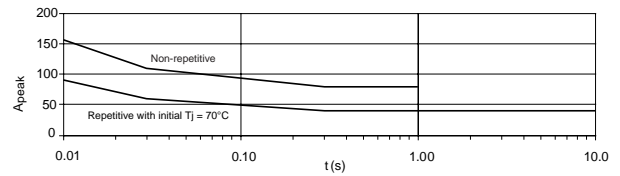

Figure 5a — HS24 relays

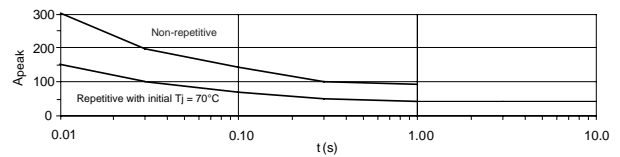

Figure 5b — HS60 relays

LOAD CURRENT DERATING CURVE

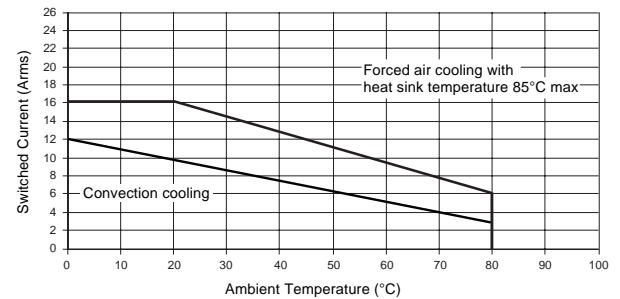

Figure 6a — HS24 relays

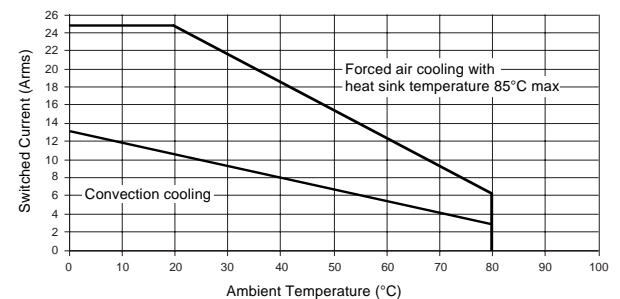

Figure 6b — HS60 relays